

LCD 1480

Category I or Category III Appliance

(see Installation and Operation Manual for venting information)

CODE OPTIONS

CSD-1	UTC Lockout/Reset Control Manual Reset LWCO
--------------	--

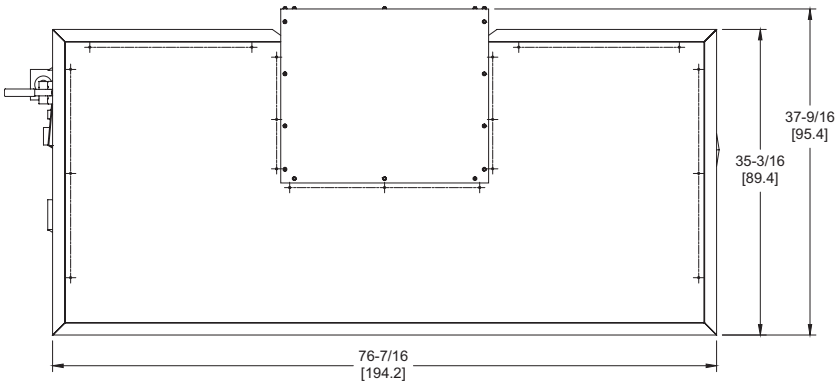

OUTDOOR TOP VIEW

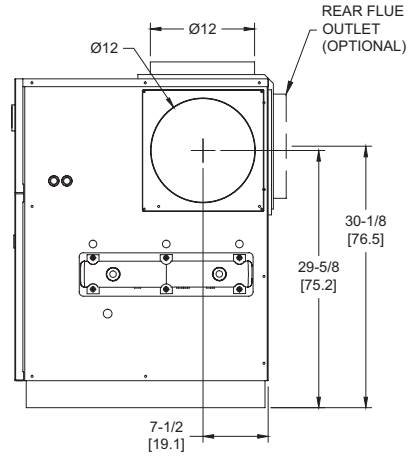

RIGHT VIEW

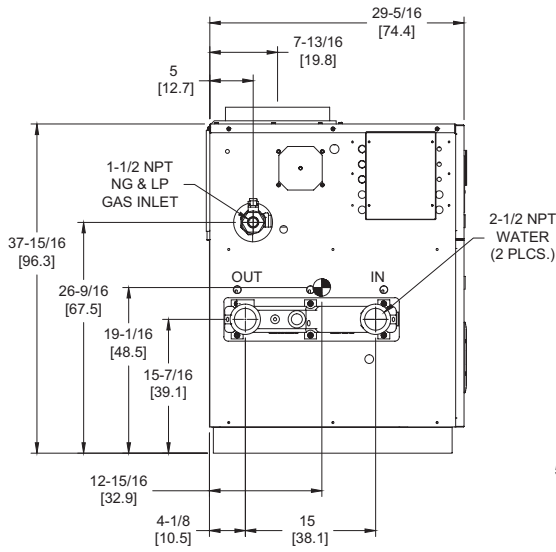

LEFT VIEW

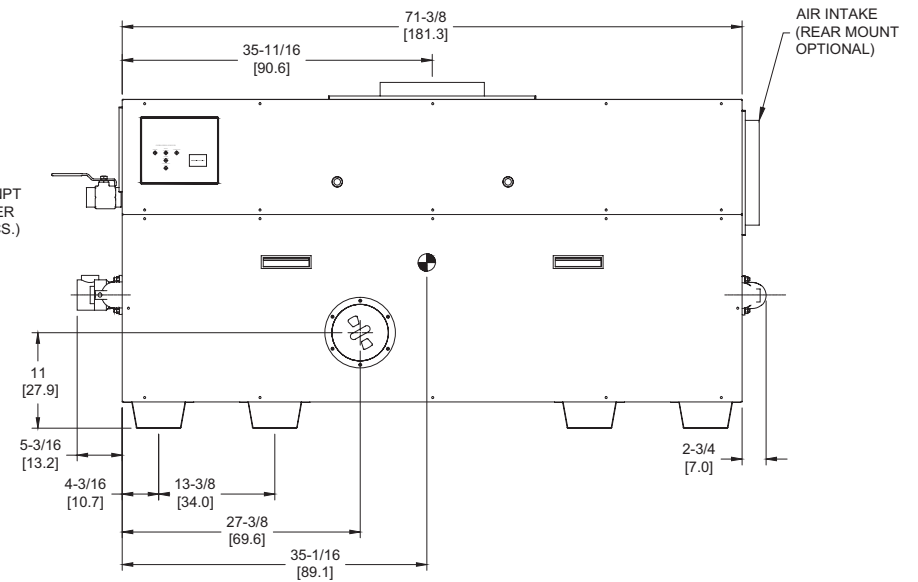

FRONT VIEW

RSUB-21-F

Notes:

1. Dimensions are approximate and should not be used to "rough-in" equipment.
2. Dimensions are subject to change without notice.
3. All dimensions are in inches (cm).
4. Symbol indicates center of gravity.

BOILER CERTIFIED RATINGS & CAPACITIES

Fuel Type	Natural/Propane Gas	Boiler FLA	11.0*
Input BTU/hr.	1,480,000 / 434 kW	Min. Gas Pressure Required	7" WC**
Output BTU/hr.	1,213,600 / 356 kW	Max. Gas Pressure Allowed	14" WC
Electrical Requirements	120VAC/ 1 ph/ 60 hz	Operating Weight	830 lbs. / 377 kg.

BOILER / WATER HEATER TRIM & CONTROLS

Main Gas Valve	Honeywell V8944B 1-1/2"	Pilot Valve	Honeywell VR8205Q
Firing Valve	Honeywell B200T1058 1-1/2"	Air Switch	Cleveland RSS-495
Safety Valve	Honeywell V48A 1-1/2"	Blower Motor	(2) 1/4 hp - FLA 10.2
Ignition Control	UTC 1003-61A	Relief Valve - LW	3/4" x 3/4" set @ 125 psi
Operating Control (LB/LW)	Jumo	Relief Valve - LB	1" x 1-1/4" set @ 50 psi
High Limit (LB/LW)	Jumo	Flow Switch	TACO

A.S.M.E.

ASME Sect IV Htg Surface	137 Sq. Ft. / 12.73 Sq. M.	Design Data	Max. 160 psig & 250°F
Water Volume	4.8 gal / 18.2 Liters		

* Add circulator amps.

** For incoming gas pressures lower than 7" WC natural or 11" WC propane, consult factory.

BOILER TEMPERATURE RISE / PRESSURE DROP

20°F / 11.1°C				25°F / 13.9°C				30°F / 16.7°C				35°F / 19.4°C			
Flow Rate		Pressure Drop		Flow Rate		Pressure Drop		Flow Rate		Pressure Drop		Flow Rate		Pressure Drop	
GPM	L/s	Ft	kPa	GPM	L/s	Ft	kPa	GPM	L/s	Ft	kPa	GPM	L/s	Ft	kPa
121.4†	7.7†	7.94	23.4	97.1	6.1	5.25	15.5	80.9	5.1	3.75	11.0	69.3	4.4	2.82	8.3

† Flow exceeds recommended maximum use a greater temperature rise or consult manufacturer.
Cupronickel heat exchanger should be considered.

WATER HEATER HOURLY RECOVERY CAPACITY (GPH & LPH)

40°F	22°C	60°F	33°C	80°F	44°C	100°F	56°C	120°F	67°C	140°F	78°C
3656	13818	2437	9212	1828	6909	1462	5527	1219	4606	1044	3948

REP FIRM _____
SUBMITTED BY _____
JOB NAME _____
ARCHITECT _____
ENGINEER _____
CONTRACTOR _____
DATE _____

LCD 1480

Category I or Category III Appliance
(see Installation and Operation Manual for venting information)

RBI®
RELIABLE. BOLD. INNOVATIVE.

A Division of Mestek, Inc.
Westfield, MA 01085
(413) 564-5515